



Algebraically Speaking

Write an equation and solve:

The perimeter of a rectangle is 48 cm and the width is half the length. What are its dimensions? (5.03)



Investigate Data

The following data represent the winning point totals for Glendale Middle School's basketball team: 23, 18, 24, 49, 26, 23, 24, 26, 28, 18, 20, 22, 47, 27, 16, 19, 30, 47, 23, 20, 27, 40, 28, 31, 28, 23

- A Determine the lower quartile, the median, and the upper quartile.
- B Determine the range.
- C Determine the mean and mode. (4.02)

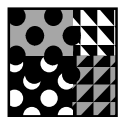

Geometry Rules

The triangles below are similar. Find the missing measurements: a , b , and c .

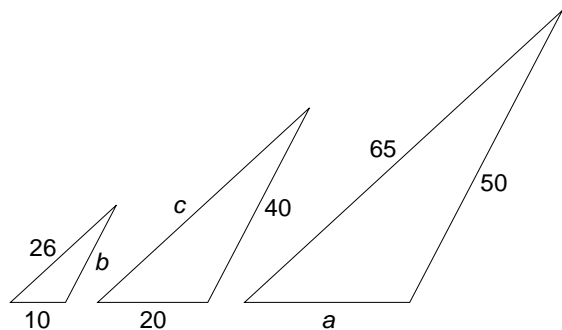

(3.03)



Mathmania

Twelve people have entered a chess tournament. Each person is scheduled to play every other person once. How many games are scheduled for the tournament?

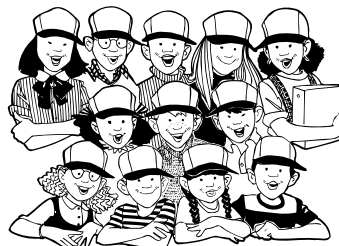

(1.03)



Solve It!

Tammy was paid \$5 an hour for washing cars. She worked 3 hours on Friday, 9 hours on Saturday and 5 hours on Sunday. Materials costs her \$32.75. How much money did she make after expenses?



(1.03)



Write On!



Explain why 4 is less than 5, but -4 is greater than -5 .

(Review)



Keeping Skills Sharp

Write answers here:

1. $25 \div (5 + 20) \times 2 =$ 1. _____
2. If $13.1 + s = 56.6$, $s = ?$ 2. _____
3. $7.5 \times 10^5 =$ 3. _____
4. 12% of 50 is what number? 4. _____
5. Give the prime factorization of 28. 5. _____
6. Find the GCF of 30 and 90. 6. _____
7. What is the perimeter of a 4 cm \times 2 cm rectangle? 7. _____
8. Simplify: $6^2 - 4 \times 3 + 2$ 8. _____
9. 83,752,245 is how many hundreds? 9. _____
10. Estimate: 62% of 151. 10. _____



Mental Math

Directions to Students:

Write your answers as the questions are called out.
Each question will be repeated only once.

- | | |
|---------|----------|
| 1 _____ | 6 _____ |
| 2 _____ | 7 _____ |
| 3 _____ | 8 _____ |
| 4 _____ | 9 _____ |
| 5 _____ | 10 _____ |

Answer Key

Grade >

WEEK
19

Algebraically Speaking

$$x + x + 0.5x + 0.5x = 48; \text{ length} = 16 \text{ cm, width} = 8 \text{ cm}$$

Geometry Rules

$$a = 25; b = 20; c = 52$$

Math Mania

66

Solve It!

\$52.25

Write On!

A number's value decreases the farther to the left it appears on a number line.

Investigate Data

lower quartile = 22, median = 25, upper quartile = 28,
range = 33, mean = 26, mode = 23

Keeping Skills Sharp

- 2
- 43.5
- 750,000
- 6
- $2^2 \times 7$
- 30
- 12 cm
- 26
- 837,522
- 90

Mental Math

This section provides an opportunity for sharpening students' mental computation.

- $5 \times 14 \div 5$
- $381 + 562$
- $\frac{9}{11} - \frac{6}{11}$
- $24 \times (-15) \times 0$
- $\sqrt{225}$
- 514×10
- $16 \text{ mm} = \underline{\quad} \text{ m}$
- $75 - (3 \times 25)$
- $560 \div ? = 8$
- $\left(\frac{1}{2}\right)^2$

Mental Math

- 14
- 943
- $\frac{3}{11}$
- 0
- 15
- 5,140
- 0.016
- 0
- 70
- $\frac{1}{4}$



Algebraically Speaking

Complete the table

$$(3 \times \square) - 2 = \triangle$$

\square	4	3	10	
\triangle	10	7	28	19

(5.03)



Investigate Data

The judges at Marcy's skating competition gave her scores of 9.6, 9.2, 9.4, and 9.3. What score would the fifth judge have to give Marcy to raise her average score to 9.4?

(4.02)

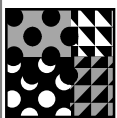

Measurement Rules

What is the volume of this rectangular prism?

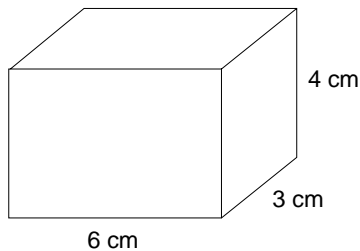

(2.02)



Mathmania

Explain how you know that 27×97 must be less than 3,000 before you do the actual computation.

(1.02)



Solve It!

The Parker's average monthly phone bill is \$56. Their new long distance service will save them \$162 each year. What will the Parker's new average be?



(1.03)



Write On!

Look at the problem below and the multiple choice answers to the problem. Explain why a student might choose each of the wrong answers. (Hint: It might be helpful to work the problem yourself first.)

$$8\frac{2}{3} + 4\frac{1}{4}$$

a. $12\frac{3}{7}$

b. $12\frac{11}{24}$

c. $4\frac{5}{12}$

d. $12\frac{3}{12}$ or $12\frac{1}{4}$

(1.02)



Keeping Skills Sharp

Write answers here:

1. If $261 - h = 67$, what is the value of h ? 1. _____
2. $P - 2.41 = 7.32$; solve for P . 2. _____
3. $3\frac{3}{4} \times 1.5 = R$; solve for R . 3. _____
4. 110% of 99 is what number? 4. _____
5. What is the prime factorization of 39? 5. _____
6. Find the least common multiple of 28 and 70. 6. _____
7. What is the perimeter of a regular hexagon whose sides are 52 cm? 7. _____
8. Simplify: $7 + 49 \div 7$ 8. _____
9. Nearest hundredth to 0.619 9. _____
10. $4^2 + 9 \times 6 - 4 =$ 10. _____



Mental Math

Directions to Students:

Write your answers as the questions are called out.
Each question will be repeated only once.

- | | |
|---------|----------|
| 1 _____ | 6 _____ |
| 2 _____ | 7 _____ |
| 3 _____ | 8 _____ |
| 4 _____ | 9 _____ |
| 5 _____ | 10 _____ |

Answer Key

Grade \rightarrow
WEEK
20

Algebraically Speaking

7

Measurement Rules

72 cm³

Solve It!

\$42.50

Write On!

- The student added numerators and added denominators and did not find a common denominator.
- The student found a common denominator, but then incorrectly added denominators.
- The student subtracted instead of added.
- The student found a common denominator, but did not convert the numerator to find equivalent fractions.

Investigate Data

9.5

Mathmania

Answers will vary.

Keeping Skills Sharp

- 194
- 9.73
- $5\frac{5}{8}$ or 5.625
- 108.9
- 3×13
- 140
- 312 cm
- 14
- 0.62
- 66

Mental Math

This section provides an opportunity for sharpening students' mental computation.

- $(27 + 4) - (8 \times 3)$
- $2^4 + 3^2$
- $25 \times 10 \times \frac{1}{25}$
- $\frac{\sqrt{4}}{\sqrt{81}}$
- -100×-1
- $\frac{3}{5} - \frac{3}{10}$
- $15 \times 2 - 45$
- $-4(2)$
- 5 cm = _____ m
- Estimate: What percent of 51 is 32?

Mental Math

- 7
- 25
- 10
- $\frac{2}{9}$
- 100
- $\frac{3}{10}$
- 15
- 8
- 0.05
- 60%



Algebraically Speaking

If $\square \square \ominus = 2x + 1$, then what would $\square \square \square \square \square \ominus \ominus$ equal?

(5.03)



Investigate Data

Dana recorded the ages of ten of her cousins and displayed the data in a box plot with only one “whisker”. Explain how this is possible. What ages would produce this type of box plot?

(4.03)

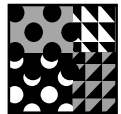

Geometry Rules

Similar triangles are shown. Find the measure of x .

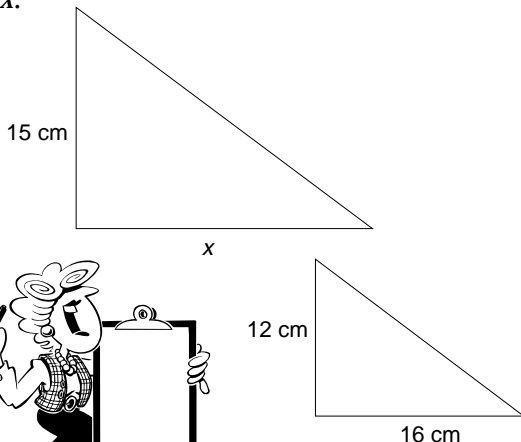

(3.03)



Mathmania

Shape A is similar to Shape B . Solve for x .

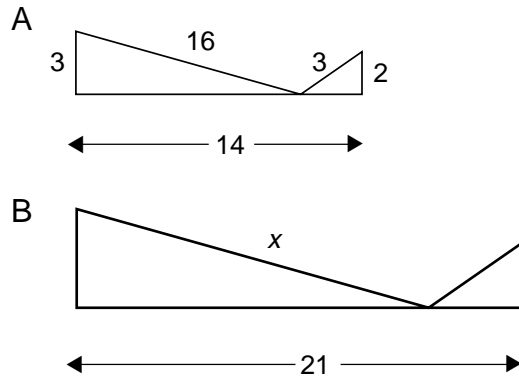

(3.03)



Solve It!

Jason bought a car for \$3,500. He sold his truck for \$1,500 which he used as a down payment. The remaining amount was borrowed at 4.5% interest for nine months. What will his monthly payments be?

(1.01, 1.03)



Write On!

Tell about a real life situation where you could use percents to compare data instead of using fractions or decimals. Why does using percents result in a more meaningful comparison than using fractions or decimals?

(1.03)



Keeping Skills Sharp

Write answers here:

1. Solve for m : $2^3 \times 15 = m$ 1. _____
2. Solve: $38.2 \times j = 0.573$ 2. _____
3. $\frac{5}{7} \div \frac{9}{14} = w + 1$ Solve for w . 3. _____
4. The price of an item changed from \$5.95 to \$6.99.
Determine the percent of increase. 4. _____
5. What is the prime factorization of 56? 5. _____
6. Find the GCF of 98 and 112. 6. _____
7. Find the circumference of the circle: 7. _____

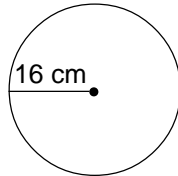

8. Simplify: $7^2 + 8^3 - 8^2$ 8. _____
9. How many tenths in 1.915? 9. _____
10. Estimate: $22\frac{1}{4} \times 4\frac{1}{3}$ 10. _____



Mental Math

Directions to Students:

Write your answers as the questions are called out.
Each question will be repeated only once.

- | | |
|--|---|
| 1 _____
2 _____
3 _____
4 _____
5 _____ | 6 _____
7 _____
8 _____
9 _____
10 _____ |
|--|---|

Answer Key

Grade >

WEEK
2 1

Algebraically Speaking

$$5x + 2$$

Investigate Data

Answers will vary.

Geometry Rules

20 cm

Mathmania

$$x = 24$$

Solve It!

\$229.72

Write On!

Students might mention the use of percents to compare data when the base amounts are different values. For instance, to compare 7 out of 20 and 9 out of 25, change 7 out of 20 to 35% and 9 out of 25 to 36%. It is now easy to see that $36\% > 35\%$.

Keeping Skills Sharp

- 120
- 0.015
- $\frac{1}{9}$
- about 17%
- $2^3 \times 7$
- 14
- about 100.5 cm
- 497
- 19
- 95 to 100

Mental Math

This section provides an opportunity for sharpening students' mental computation.

- $K - 9.5 = 10$; $K = ?$
- $L - \$3.40 = \5.60 ; $L = ?$
- $\frac{10}{28} = \frac{N}{14}$; $N = ?$
- $6 \times P = 420$; $P = ?$
- $32 = F^5$
- $\frac{3}{5} - \frac{3}{15}$
- $3^2 + (9 \times 5) + 4$
- $-35 \div 5 - (-3)$
- What is the difference between 32 and 17?
- $3L = \underline{\hspace{2cm}} \text{ mL}$

Mental Math

- 19.5
- \$9
- 5
- 70
- 2
- $\frac{6}{15}$ or $\frac{2}{5}$
- 58
- 4
- 15
- 3,000