

Solving Equations Square Puzzle

$51 = x^2 - 7$ $4 - 3x = 34$ 4.5 4 3 $-$	$51 = x^2 - 7$ $0 = x^2 + 3$ $12x + 6 = -10$ 3 30 3 $2 = 3 - 5x$	$51 = x^2 - 7$ $0 = x^2 + 3$ $12x + 6 = -10$ $1 - 9x = 4$ 5 3 4 $1 = 1 + 4x$	$51 = x^2 - 7$ $0 = x^2 + 3$ $12x + 6 = -10$ $1 - 9x = 4$ 5 3 4 $1 = 1 + 4x$
$51 = x^2 - 7$ $4 - 3x = 34$ 4.5 4 3 $-$	$51 = x^2 - 7$ $0 = x^2 + 3$ $12x + 6 = -10$ $1 - 9x = 4$ 5 3 4 $1 = 1 + 4x$	$51 = x^2 - 7$ $0 = x^2 + 3$ $12x + 6 = -10$ $1 - 9x = 4$ 5 3 4 $1 = 1 + 4x$	$51 = x^2 - 7$ $0 = x^2 + 3$ $12x + 6 = -10$ $1 - 9x = 4$ 5 3 4 $1 = 1 + 4x$
$51 = x^2 - 7$ $4 - 3x = 34$ 4.5 4 3 $-$	$51 = x^2 - 7$ $0 = x^2 + 3$ $12x + 6 = -10$ $1 - 9x = 4$ 5 3 4 $1 = 1 + 4x$	$51 = x^2 - 7$ $0 = x^2 + 3$ $12x + 6 = -10$ $1 - 9x = 4$ 5 3 4 $1 = 1 + 4x$	$51 = x^2 - 7$ $0 = x^2 + 3$ $12x + 6 = -10$ $1 - 9x = 4$ 5 3 4 $1 = 1 + 4x$
$51 = x^2 - 7$ $4 - 3x = 34$ 4.5 4 3 $-$	$51 = x^2 - 7$ $0 = x^2 + 3$ $12x + 6 = -10$ $1 - 9x = 4$ 5 3 4 $1 = 1 + 4x$	$51 = x^2 - 7$ $0 = x^2 + 3$ $12x + 6 = -10$ $1 - 9x = 4$ 5 3 4 $1 = 1 + 4x$	$51 = x^2 - 7$ $0 = x^2 + 3$ $12x + 6 = -10$ $1 - 9x = 4$ 5 3 4 $1 = 1 + 4x$

Cut out the squares above. Fit the squares together so that touching edges match an equation to its solution.

How Do They Fit?

$y < -4$ $y > \frac{1}{2}$ $y + 1 < -2$	$y + 2 < 8$ $y > -4$ $12y < -6$ $-7y > 7$	$y > -6$ $y > -3$ $y - 8 > -12$ $\frac{-y}{3} > \frac{-3}{5}$
$y > -3$ $y > \frac{2}{3}$ $\frac{2}{y} > 2$ $y < -1$ $\frac{y}{2} < -1$	$y < 5$ $y < \frac{1}{2}$ $7y < -14$ $y < 3$ $-2y < -6$ $15y < 3$	$y < 5$ $y + 3 > 5$ $y < 2$ $y < -7$ $-2y < -8$ $y > 4$
$y < 4$ $y > 2$ $5y > 15$ $y > \frac{1}{3}$ $-6y > -2$	$-2 < y$ $y > 1$ $y > -1$ $-9y > -2$	$y < 2$ $y > 4$ $y - 4 < -3$ $-8 < -7$

Cooperative Problem Solving with Patterns

<p>Problem A A porpoise is swimming and jumping in a motion that produces a pattern . Sometimes he is above sea level and sometimes he is under the sea. The numbers show how high or deep he is as compared to sea level.</p>	<p>Problem A At 1:00 pm, the porpoise is 9 feet above the ocean surface. At 1:02 pm, he is only 6 feet above sea level.</p> <p>Find the height of the porpoise at 1:10 pm.</p>
<p>Problem A At 1:01 pm, the porpoise is 1 foot under water. But at 1:04 he is 3 feet above the water.</p> <p>Find the height of the porpoise at 1:10 pm.</p>	<p>Problem A At 1:03 pm, the porpoise is 4 feet under water. And at 1:05 he is 7 feet under water.</p> <p>Find the height of the porpoise at 1:10pm.</p>

<p>Problem B John's calculator is broken. Every time he hits the enter key, the calculator does the same operation to the answer in the screen.</p> <p>What number was on the screen after the enter key was hit three times?</p>	<p>Problem B The number on the screen of the calculator before it was discovered to be broken was a -5. After the enter key is hit twice, the number on the screen is -20.</p> <p>What number was on the screen after the enter key was hit three times?</p>
<p>Problem B After the enter key was hit five times, the number on the screen is 160.</p> <p>What number was on the screen after the enter key was hit three times?</p>	

Cooperative Problem Solving with Patterns

<p>Problem C An archaeologist found an ancient clay tablet on which students from long ago were writing a fraction pattern. The first fraction was broken off the tablet. Find the first fraction.</p>	<p>Problem C The first fraction visible on the tablet appears to be the second fraction in the pattern. This second fraction is $\frac{7}{10}$. Find the first fraction.</p>
<p>Problem C The denominator of the third fraction is not clear, but the numerator is visible. The third fraction looks like $\frac{9}{\text{■}}$ and the fourth fraction is $\frac{11}{40}$. Find the first fraction.</p>	<p>Problem C The fifth and sixth fractions look like This: $\frac{\text{■}}{80}$ and $\frac{15}{160}$. Find the first fraction.</p>

<p>Problem D A hiking party wants to climb a path that winds 2700 feet up a mountain path that gets steeper and steeper. They begin at noon, and during the first hour they travel 1800 feet and have 900 feet left to go. At what hour will they be within 10 feet of the top?</p>	<p>Problem D At 2:00 pm they have traveled a total distance of 2400 feet, but they still have 300 feet of very steep terrain to cover. At what hour will they be within 10 feet of the top?</p>
<p>Problem D From 2:00 till 3:00 they travel another 200 feet, and there are 100 feet to go. If their progress follows this same pattern, at what hour will they be within 10 feet of the top?</p>	<p>Problem D Hint: Make a chart with columns for time, distance traveled, and distance remaining. At what hour will they be within 10 feet of the top?</p>

Cooperative Problem Solving with Patterns

<p>Problem E Joe's friends have a band. They want Joe to help them make CD copies of their music to sell to fans. After doing some research on the software he would need and the price for supplies, Joe finds that making ten CDs would cost him \$80.</p>	<p>Problem E The friends think they may want more than ten copies, so they ask Joe for some other prices. He tells them that 100 copies would cost him \$350 and 1000 copies would cost him \$3050.</p>
<p>Problem E The friends decide to buy 50 copies from Joe. If they sell the CDs for \$8 each, how many copies must they sell to have enough to pay Joe's bill?</p>	
<p>Problem F Mrs. Avonia has a door to door cosmetics business that she started in January. She has been looking for receipts so she can check on the number of customers she had. She finds that she had four customers in January.</p>	<p>Problem F She remembers that she had 26 customers in May; however when she finds her receipts for February, she notices that she had only six customers that month.</p>
<p>Problem F She finally finds her receipts for March and April and finds that she had ten customers in March and 16 the month after that.</p>	<p>Problem F "Aha!" cries Mrs. Avonia. "I see a pattern here!" How many customers should she predict for the months of June and July?</p>

Cooperative Problem Solving with Patterns

<p>Problem G A local baseball stadium is trying to plan for an upcoming exhibition game. Records show that when they had a crowd of 20,000 fans, they sold 16,000 hotdogs.</p>	<p>Problem G Last year they had a crowd of 32,000, and they sold 25,600 hotdogs. The lowest turnout they ever had for this event was 15,000 and they sold 12,000 hot dogs that year.</p>
<p>Problem G They buy hot dogs in bulk packages of 64. The buns come 48 in a pack.</p>	<p>Problem G This year they expect a record turnout of 48,000 fans. How many packages of hot dogs and buns should they buy?</p>
<p>Problem H The band is planning a bake sale to raise money for a trip. In years past, the parents signed up to contribute cakes and the band set up the tables and conducted the sale.</p> <p>The first year of the sale, 24 parents signed up and they made a total of 30 cakes to sell.</p>	<p>Problem H The second year of the sale more parents participated. Forty signed up, and they contributed 50 cakes.</p>
<p>Problem H In the third year, the PTA got involved. Sixty parents signed up and they baked 75 cakes for the sale.</p>	<p>Problem H This year the entire community is involved. The number of adults signing up to bake cakes is 160. If the tables can hold 25 cakes each, how many tables should the band set up for the sale?</p>

Perimeter and Area Patterns

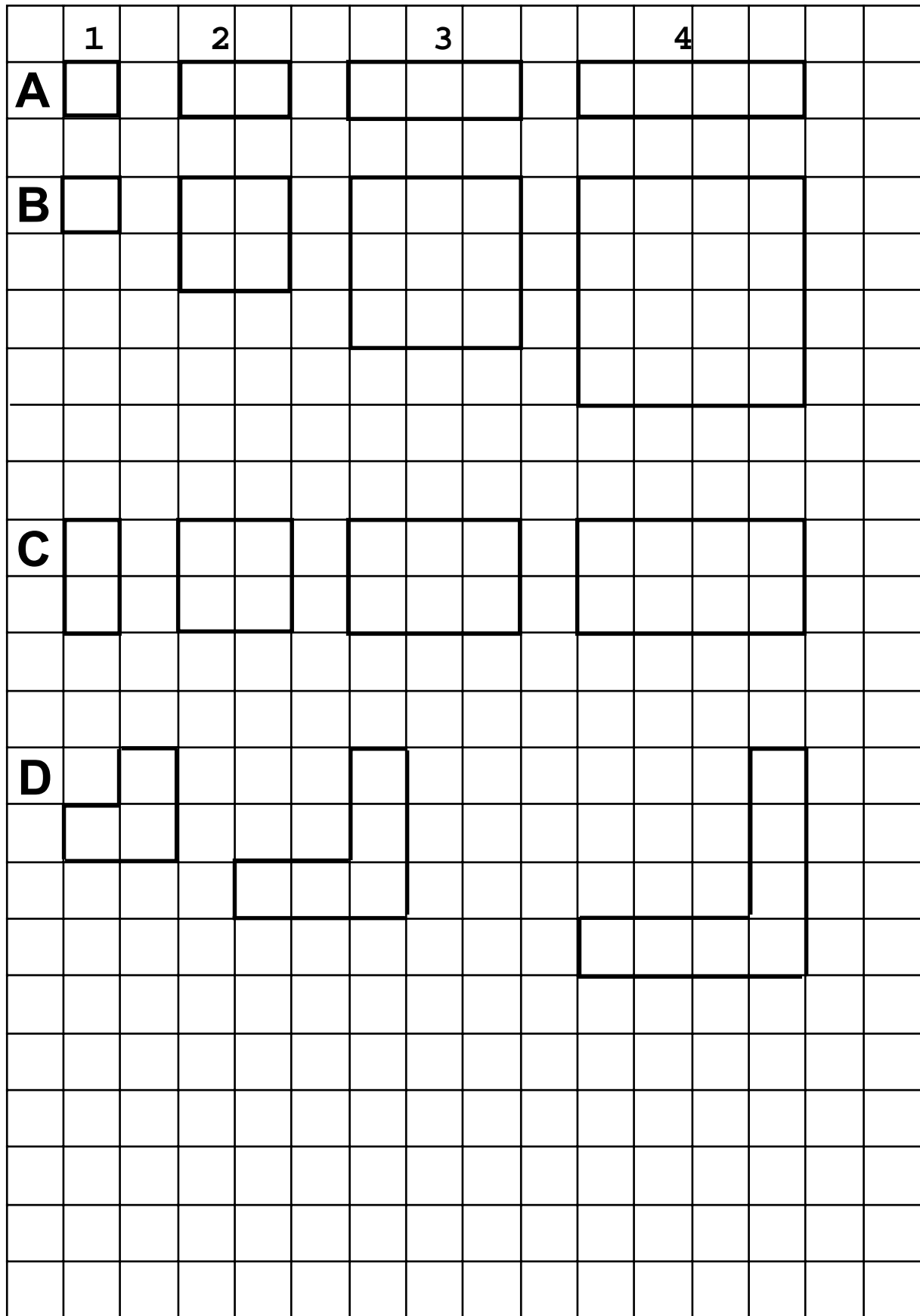

Perimeter and Area Patterns Recording Page

Complete the charts below for the four geometric patterns on the previous page. Can you predict the areas and perimeters for the figures not shown? Can you find a formula for the n th figure in the pattern? That is, can you find a formula with n as a variable that will help you calculate the area or perimeter when you plug in a number for n , the figure number in the pattern?

Pattern	Number	Perimeter	Area	Pattern	Number	Perimeter	Area
A	1	_____	_____	B	1	_____	_____
A	2	_____	_____	B	2	_____	_____
A	3	_____	_____	B	3	_____	_____
A	4	_____	_____	B	4	_____	_____
A	5	_____	_____	B	5	_____	_____
A	10	_____	_____	B	10	_____	_____
A	100	_____	_____	B	100	_____	_____
A	1000	_____	_____	B	1000	_____	_____
A	n	_____	_____	B	n	_____	_____

Pattern	Number	Perimeter	Area	Pattern	Number	Perimeter	Area
C	1	_____	_____	D	1	_____	_____
C	2	_____	_____	D	2	_____	_____
C	3	_____	_____	D	3	_____	_____
C	4	_____	_____	D	4	_____	_____
C	5	_____	_____	D	5	_____	_____
C	10	_____	_____	D	10	_____	_____
C	100	_____	_____	D	100	_____	_____
C	1000	_____	_____	D	1000	_____	_____
C	n	_____	_____	D	n	_____	_____

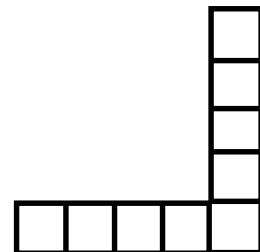
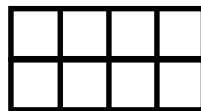
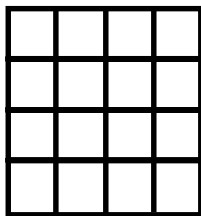

$$5x + 2$$

$$2x + 2y + 3y + 2x$$

$$7x - 3$$

$$4x + 6 + x - 4$$

$$4x + 5y$$

$$3x + 3$$

$$5x - 4 + 2x + 1$$

$$3(x + 1)$$

$$x^2 + 2$$

$$2x + 2$$

$4x$	$2x^2$
$x + x + 2$	$2x + 2x$
$2 + x^2$	$x^2 + x^2$
$5y + 4x$	$7x - 1$
$4(x + y) + y$	$-2 + 5x + 2x + 1$

Equation Dominoes

★ $12 + 4x = 36$	When Joe is 12 years older, he will be 36. How old is he now? ★	★ $x + 12 = 36$	If Tom had twice as much money as he has now, he would have \$36. How much does he have now? ★
★ $2x = 36$	When 36 brownies are shared among all club members, each gets 12. how many club members are there? ★	★ $\frac{36}{x} = 12$	Joe is 2 years older than his brother. The sum of their ages is 12. How old is Joe's brother? ★
$x + (x + 2) = 12$ ★	Two years ago, Joe was 36 years old. How old is he now? ★	★ $x - 2 = 36$	When a package of candy is shared among 12 friends, each gets 36 pieces. How many pieces of candy were in the package? ★
★ $x = 36$ 12	After Tom reads 36 pages of his magazine, he still has 12 pages to read. How many pages are in the magazine? ★	$x - 36 = 12$ ★	Pete's dog weighs 12 pounds more than Joe's dog. The dogs weigh 36 pounds together. How much does Joe's dog weigh? ★
★ $x + (x + 12) = 36$	Joe bought 36 ride tickets. The total cost for tickets is \$9. How many ride tickets were bought at the fair? ★	★ $36x = 9$	When an athletic team is divided into two groups, each group has 36 people in it. How many people are in the team? ★

$\frac{x}{2} = 36$	<p>Five statues are in a box that weighs one pound. The total weight is 36 pounds. How much does each statue weigh?</p>	$5x + 1 = 36$	<p>A family of 5 gets a \$4 discount on their dinner bill. The total cost is \$36. What would be the cost for each person with no discount?</p>
$5x - 4 = 36$	<p>Five envelopes each contain the same amount of money. After \$14 is removed, \$36 is left. How much was in each envelope?</p>	$5x - 14 = 36$	<p>Joe has some baseball cards, and his brother has $\frac{1}{3}$ as many as Joe. Together, they have 36. How many cards does Joe have?</p>
$x + \frac{1}{3}x = 36$	<p>Joe wants to deal a deck of 12 cards equally among the players. Each one gets six cards, how many players are there?</p>	$\frac{12}{x} = 6$	<p>Joe has some baseball cards, and his brother has $\frac{1}{3}$ as many as Joe. Joe has \$36 more than his brother. How many does Joe have?</p>
$x - \frac{1}{3}x = 36$	<p>Joe has \$36. The amount he has is \$2 more than half the amount his brother has. How much does his brother have?</p>	$\frac{1}{2}x + 2 = 36$	<p>There are 36 members at a club meeting. After some leave, there are 27 left. How many members left?</p>
$36 - x = 27$	<p>Moe bought a box of cookies. He had a dozen more at home. When he divides them among six people, each gets 7. How many in a box?</p>	$\frac{x + 12}{6} = 7$	<p>Joe has \$36. After he goes to the movies twice, he has \$6 left. How much did it cost to go to the movies each time?</p>
$36 - 2x = 6$	<p>Joe has \$36. After he buys 12 tapes, he has \$18 left. How much does each tape cost?</p>	$36 - 12x = 18$	<p>Joe has 12 baseball cards. He buys four Packs and then he has a total of 36 cards. How many cards are in each pack?</p>

Over 40

Inequality

Score

Score

Inequality

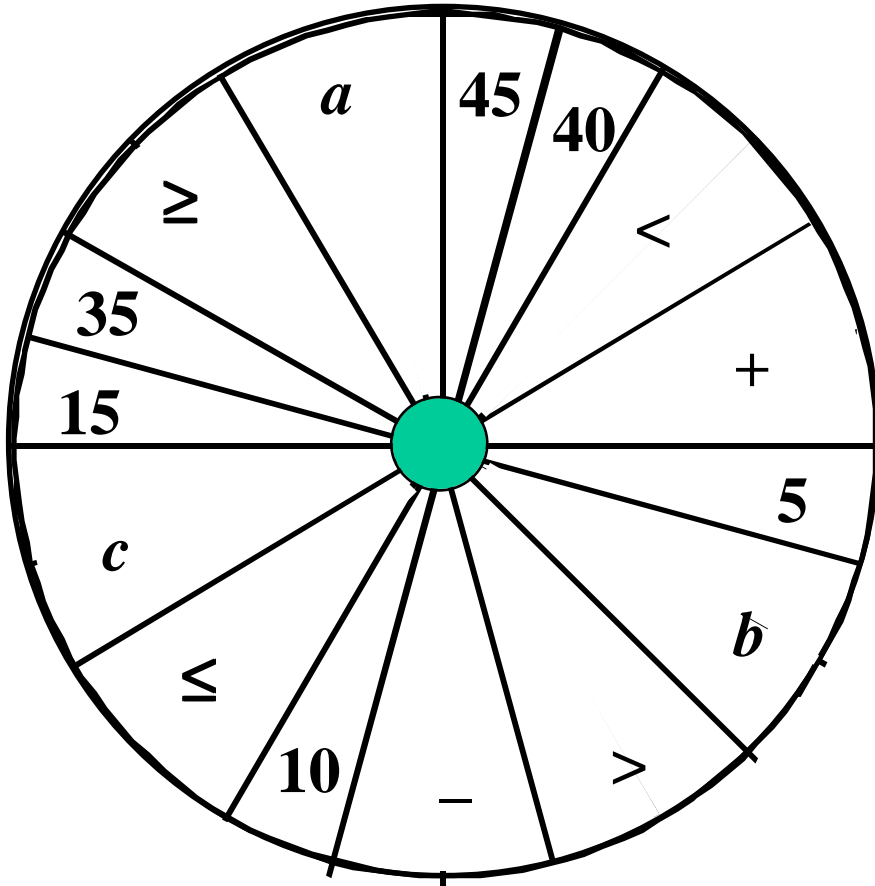

Inequality

Score

$a = 10, b = 20, c = 30$

Scoring: Each $a, b,$ or c are worth 2 points. All others are worth 1 point.

Score Inequality

Inequality Match

<p>Bill wants to buy a concert ticket to see the group Bomber. He only has \$16 which is not enough.</p> <p>B = cost of Bomber ticket.</p>	<p>Mark's package weighs 1 pound, but Brett's package is heavier.</p> <p>B = weight of Brett's package in ounces.</p>	<p>When the bus leaves school, it travels 16 miles to Tom's stop. Brad gets off the bus at the next stop.</p> <p>B = the distance from Brad's stop to the school.</p>
<p>Bell buys a shirt for \$16. Tax is added to the total.</p> <p>B = amount Bell pays.</p>	<p>Bob has a model rocket that is 16 inches tall. His model of the booster rocket is shorter.</p> <p>B = height of the booster model in inches</p>	<p>Joe is 16 years old, but he has a younger brother, Biff.</p> <p>B = Biff's age.</p>
<p>Carl worked 16 hours at the car wash. His friend Bud didn't have to work as long.</p> <p>B = number of hours Bud worked at the car wash</p>	<p>The tallest tree in Don's yard is an oak which is 16 feet tall. There is also a balsam tree in the yard.</p> <p>B = height of the balsam tree in feet</p>	<p>Mark wants to buy five magazines, but he only has \$16 which is not enough.</p> <p>B = price of one magazine</p>

Inequality Match

<p>When Tom tries to mail five identical books to his cousin Joe, he finds that the package weighs more than one pound.</p> <p>B = weight of one book in ounces</p>	<p>Bill has enough gas to drive 16 miles, but he runs out of gas before he can make five round trips from home to school.</p> <p>B = round trip distance from Bill's home to school</p>	<p>Marcie has \$16. With this, she can buy four bottles of shampoo, but she doesn't have enough to buy five bottles.</p> <p>B = cost of one bottle of shampoo</p>
<p>Donna has five sections of brick border to put along her flower garden. The five sections are not enough to cover the 16 feet she needs.</p> <p>B = length of one section of border</p>	<p>In Brenda's state, the minimum driving age is 16. If Brenda were five times as old as she is now, she still would not be old enough to drive.</p> <p>B = Brenda's age now.</p>	<p>Betty is babysitting to earn money. If she works for 5 hours, she still won't have the \$16 she wants for a shirt.</p> <p>B = Betty's hourly wage for babysitting.</p>
<p>Earl wants to make a banner 16 feet long. If he glues five poster boards end to end, the banner still won't be long enough.</p> <p>B = length of one piece of poster board</p>	<p>A bush in Bob's yard was 5 feet tall last year. This year it is over 16 feet tall.</p> <p>B = amount the bush grew in the last year (in feet)</p>	<p>Frank has \$16. He does not have enough to buy a movie ticket for \$5 plus refreshments.</p> <p>B = price of refreshments</p>

Inequality Match

<p>When George packs his baseball which weighs 5 ounces and his bat, the total package weighs more than 1 pound.</p> <p>B = weight of the bat in ounces</p>	<p>Harry lives 16 miles from the state line. He drives 5 miles to the gas station and from there to a park over the state line.</p> <p>B = distance from the gas station to the park</p>	<p>Ina can buy a \$5 book plus a CD, and the total including tax is \$16.</p> <p>B = cost of the CD</p>
<p>Jack is 5 feet tall. When he stands on a ladder, he still can't reach to a height of 16 feet.</p> <p>B = height of the ladder in feet.</p>	<p>In Bonnie's state, the minimum driving age is 16. If Bonnie were five years older, she still would not be old enough to drive.</p> <p>B = Bonnie's age now.</p>	<p>Betty has \$5. She does a babysitting job, but she still doesn't have enough to pay for a \$16 CD that she wants.</p> <p>B = Betty's earnings from babysitting</p>
<p>Bert has a container of soft drink. After he pours out a 5-ounce cup, he still has more than a pint left in the container.</p> <p>B = amount of soft drink originally in the container (in ounces)</p>	<p>Students are planning a field trip. After five of them change their minds about going, there are still too many to fit in a 16-passenger mini-bus.</p> <p>B = number of students originally planning to go</p>	<p>The price of a pair of jeans is reduced by \$5. Bob has \$16, but that still is not enough to pay for the jeans.</p> <p>B = price of jeans before the discount</p>

Inequality Match

<p>In Brad's state, the minimum driving age is 16. Brad's older brother was driving over five years ago.</p> <p>B = Brad's brother's age</p>	<p>Bob loaned \$5 to his brother. Now Bob doesn't have enough money to buy a model that costs \$16.</p> <p>B = amount of money Bob had before the loan</p>	<p>Bill leaves his home and drives for 5 miles. He is now less than 16 miles from his cousin's house.</p> <p>B = distance from Bill's house to his cousin</p>
<p>Bernie is swimming in a pool. When he dives 5 feet below the surface, he is less than 16 feet from the bottom.</p> <p>B = depth of the pool</p>	<p>Belanna is making candy to ship to her friend. Her brother removes 5 ounces of the candy, and now there is less than a pound to ship.</p> <p>B = original weight of the candy</p>	<p>Five students are helping their teacher carry some papers. When each student has an equal amount to carry, each still has over a pound.</p> <p>B = weight (in ounces) of all the papers.</p>
<p>A class is planning to go on a field trip. When the students are separated into five equal groups, each group still has over 16 students.</p> <p>B = total number of students</p>	<p>The cost of a birthday present is being shared by five friends. Each one has to pay over \$16.</p> <p>B = cost of the birthday present</p>	<p>Five friends are painting a fence. Each one has to paint over 16 square feet.</p> <p>B = total area of the fence</p>

Inequality Match

<p>The average age of five friends is less than 16 years.</p> <p>B = sum of their ages</p>	<p>A package contains five equal boxes. Each box weighs less than a pound.</p> <p>B = weight of the package in ounces</p>	<p>A group of five friends go to a restaurant and share the bill equally. Each one pays less than \$16.</p> <p>B = total amount of the restaurant bill</p>
<p>Five students conduct a survey of all teenagers on their block. They each question the same number of people, but each questions fewer than 16 people.</p> <p>B = total people surveyed on the block</p>	<p>Bob pays the same amount for 16 candy bars. The total is over \$5.</p> <p>B = price of one candy bar</p>	<p>A turtle travels at a constant rate for 16 hours. He travels over 5 miles.</p> <p>B = turtle's rate of speed in miles per hour</p>
<p>A group of 16 students contribute the same amount to make a total that is over \$5.</p> <p>B = amount each student paid</p>	<p>A rectangle has a length of 16 inches. The area is over 5 square inches.</p> <p>B = width of the rectangle in inches</p>	<p>A rectangle has a length of 16 inches. The area is less than 5 square inches.</p> <p>B = width of the rectangle</p>

Inequality Match

<p>Billy pays the same amount for each of 16 phone calls. The total cost of the calls is less than \$5.</p> <p>B = price paid per call</p>	<p>Sixteen copies of the same magazine are in a stack. The stack is less than 5 inches tall.</p> <p>B = thickness of one magazine</p>	<p>A radio station plays 16 ads of equal length, The total time required for all the ads is less than 5 minutes.</p> <p>B = time for one ad</p>
<p>$16B > 5$</p>	<p>$16B < 5$</p>	<p>$B - 5 < 16$</p>

Inequality Match

$5B > 16$	$B + 5 < 16$	$\frac{B}{5} > 16$
$B < 16$	$B + 5 > 16$	$\frac{B}{5} < 16$
$B > 16$	$5B < 16$	$B - 5 > 16$



Luis is a master craftsman who can make incredible snowboards.

To open a shop he needs a license to operate a business (\$50) and a sign for his shop (\$400).

For each snowboard he makes, he spends \$35 in materials and he pays \$6 for labor.

This formula gives him the cost, C , for making n snowboards. $C = 450 + 41n$

1. Explain why the formula works.
2. If Luis can find a sign maker to make the sign for \$250, what will the formula look like?
3. Using the original formula above, if Luis makes 20 snowboards, how much will it cost him?
4. How much does it cost to make 100 snowboards?
5. At the end of one week, Luis had spent \$860 in production costs. How many snowboards did he make that week?
6. Luis sells each snowboard for \$125. If he sells 100 snowboards, how much money does he bring in from the sales?
7. What will his profit be if he sells 100 snowboards?
8. Write a profit formula for Luis that shows his profit if he sells n snowboards.
9. Luis decides he needs to use more outside labor. He will now pay \$15 in labor for each snowboard made. What will his cost formula look like now?
10. How much will it now cost to make 100 snowboards.
11. After increasing the amount he pays for labor, what will his profit formula look like?
12. Using the new profit formula, determine his profit if he sells 100 snowboards?

Music Lover's Special

At the Music Barn, all CDs are \$12.50. All cassette tapes are \$7.25, and there are some old record albums that cost \$25.00 each. Stevie loves music and he's going shopping. He has \$200 that he can spend. The prices listed include tax.

A formula for the total amount spent on music is

$$P = 12.50C + 7.25T + 25A$$

where P is the total price of all the music purchased,

C is the number of CDs purchased,

T is the number of tapes purchased, and

A is the number of albums purchased.



1. If Stevie buys 5 CDs, 3 tapes and 1 album, how much does he spend?
2. What is the maximum number of CDs he can buy?
3. What is the maximum number of tapes he can buy?
4. The shop owner has a special deal. For every purchase of a CD or tape, the shopper can buy one album at half price. With this deal, what is the maximum number of albums Stevie can buy?
5. Stevie really wants one album badly. If he buys that, what is the maximum number of tapes he can buy? (Remember the special offer described in problem four.)
6. Stevie has a CD player in his home and a cassette player in his car. He has decided to buy a tape every time he buys a CD so he can enjoy the music in both places. If he forgets the album, what is the maximum number of CDs he can buy?
7. Can you make up a problem using this formula? Make a difficult one that might stump others in the class.

Fast Formula

Jeff is on a giant water slide 50 feet tall. His science teacher gave him a formula that he can use to determine how high he is above the ground after sliding for a given amount of time. H represents his height above the ground; the variable t represents how many seconds he has been sliding.

$$H = 50 - 2t^2$$

1. Mark an X on the slide at the point where he was 1 second after he started sliding.
2. Mark a P on the slide at the point where he will be after 2 seconds.
3. How many feet did he drop between the first and second seconds?
4. How many feet did he drop between the second and third seconds?

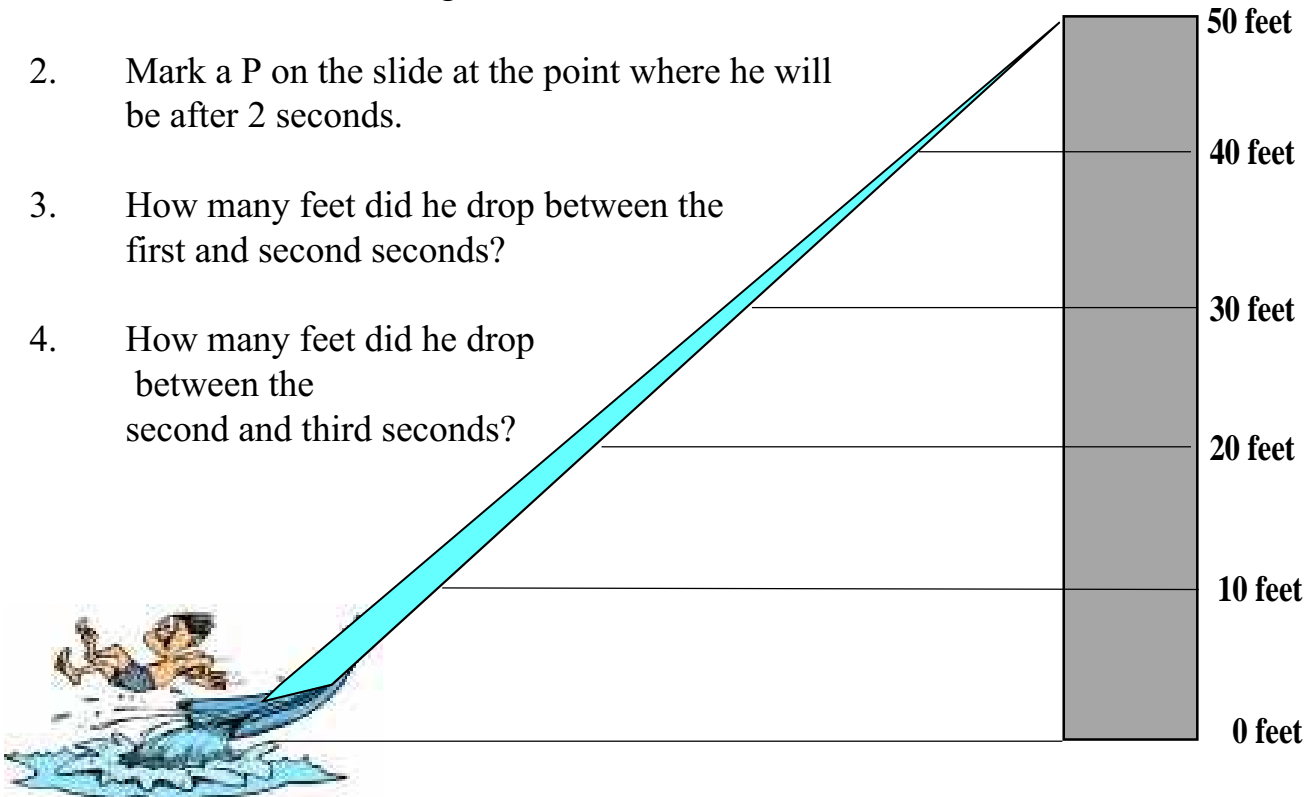

5. About how long did it take him to reach a height of 30 feet above the ground?
6. About how long will it take him to travel half way down the slide?
7. About how long will it take him to reach the bottom?
8. How many feet did he drop between the fourth and fifth seconds?

Cook's Trick

Darryl's restaurants have been serving some salads and other dishes on very long, elliptical plates. Customers can hardly believe their eyes when the dish arrives. It looks much larger than an entrée served on a normal sized dinner plate.

If the normal plate has a 12 inch diameter, what is the area of the plate?

The formula for the area of an ellipse is $\frac{1}{2} AB$ where **A** is half of the major axis (long "diameter")

and **B** is half of minor axis the (shorter "diameter").

If the oval plate has a "width" of six inches, how "long" would it have to be to have the same area as the circular plate?

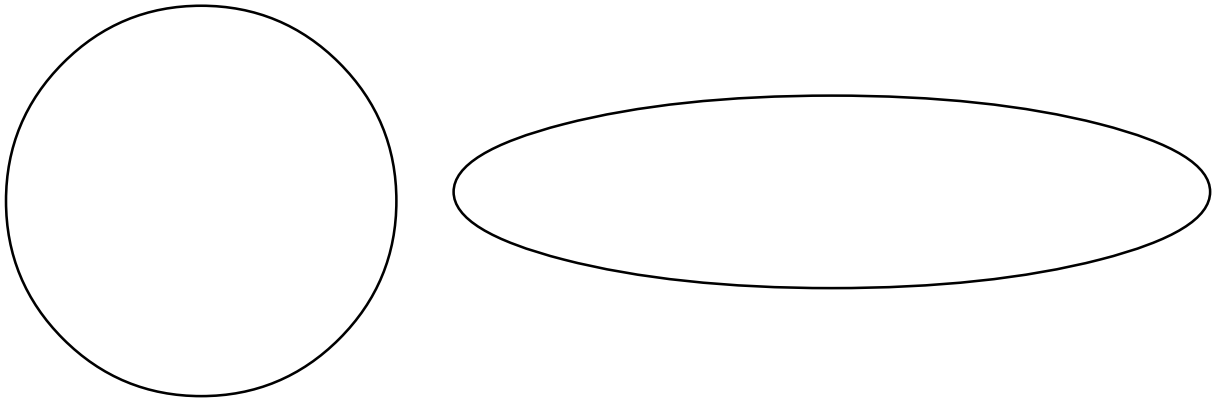

If the elliptical plate is 18 inches long and 5 inches wide, and the dinner plate has a diameter of 12 inches, which plate holds more? What is the percent of increase/decrease in the area? (Use the round plate as the basis for this comparison.)



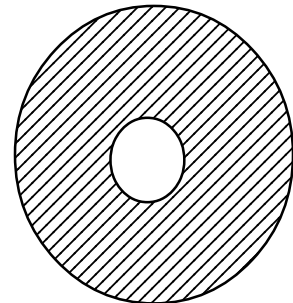
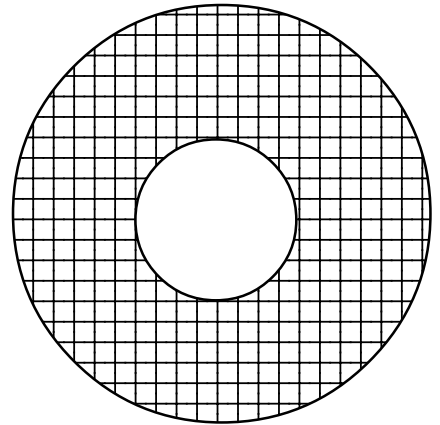
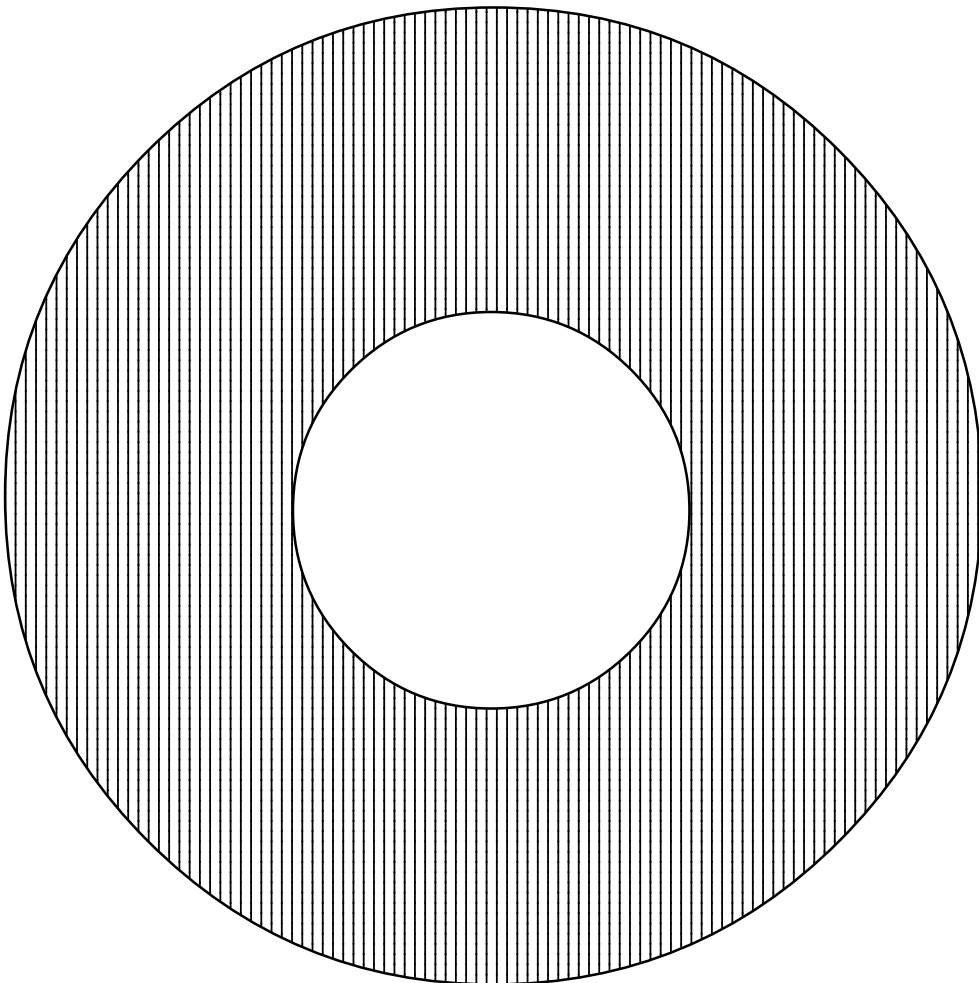
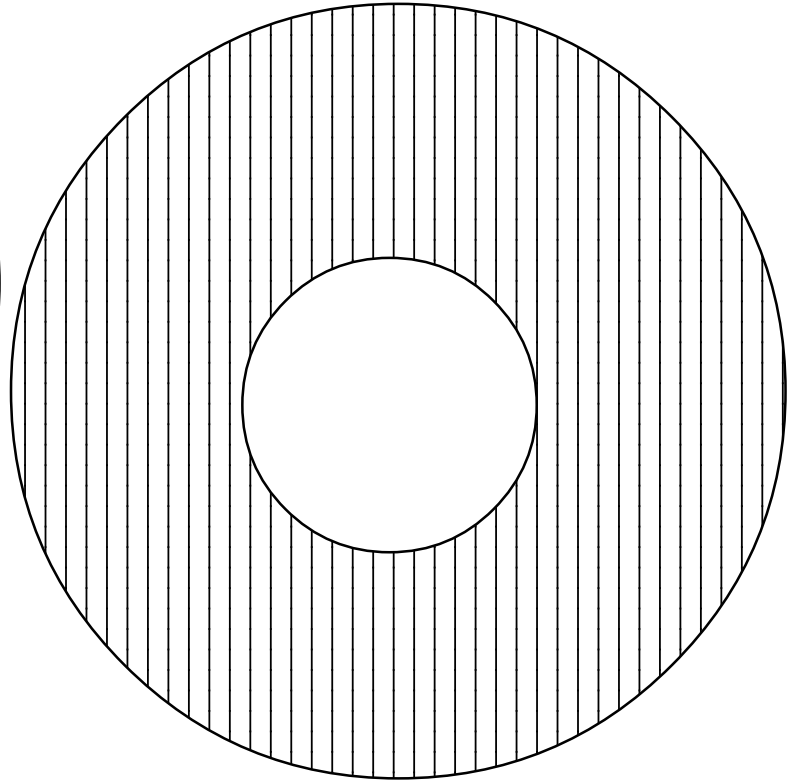
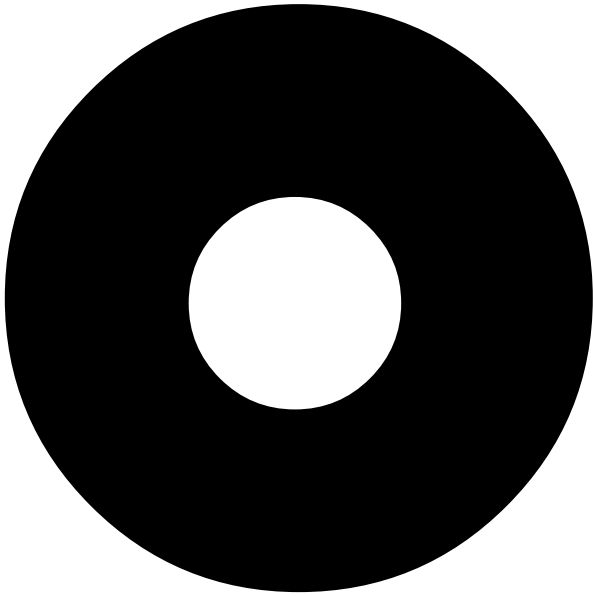

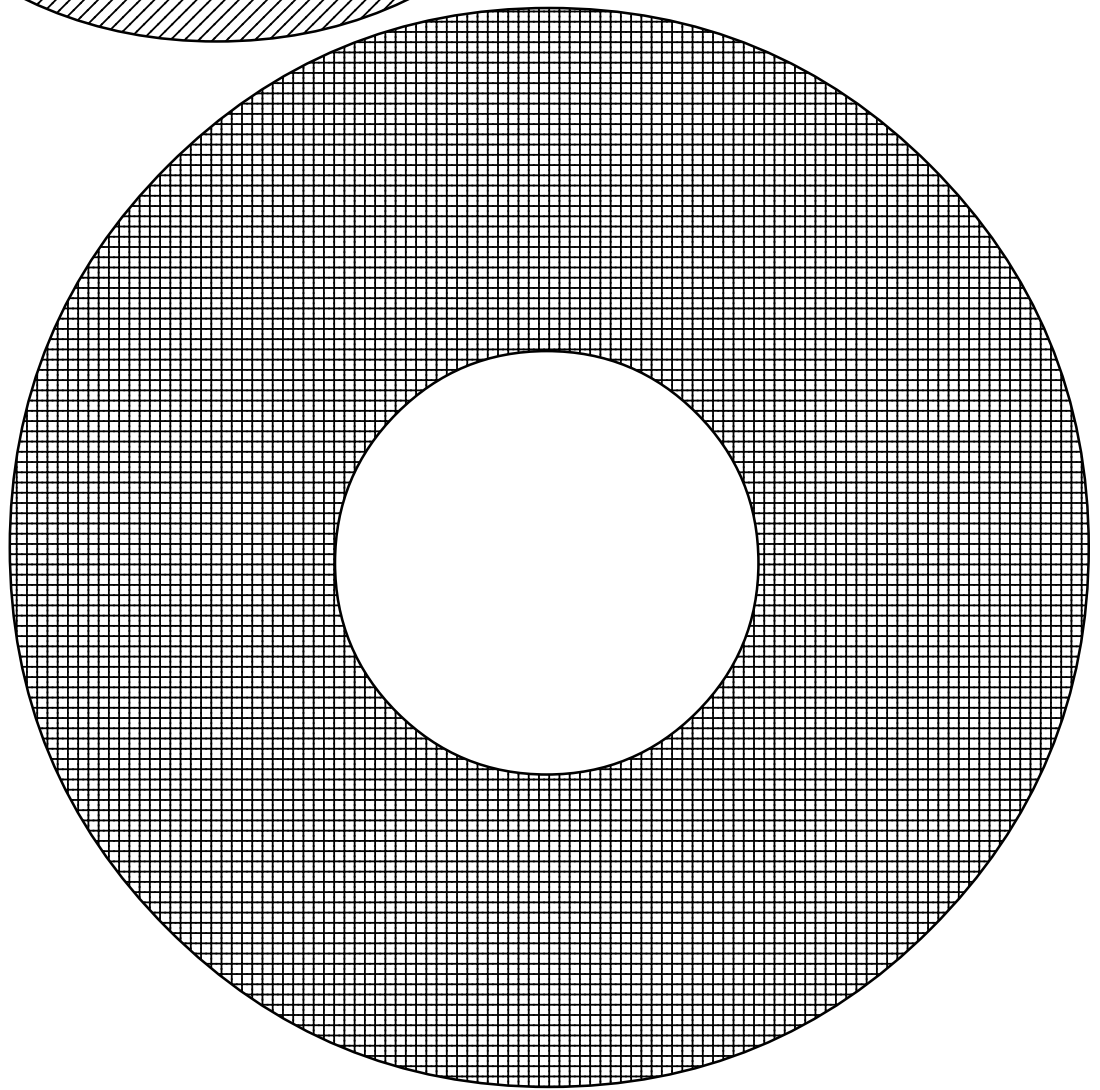
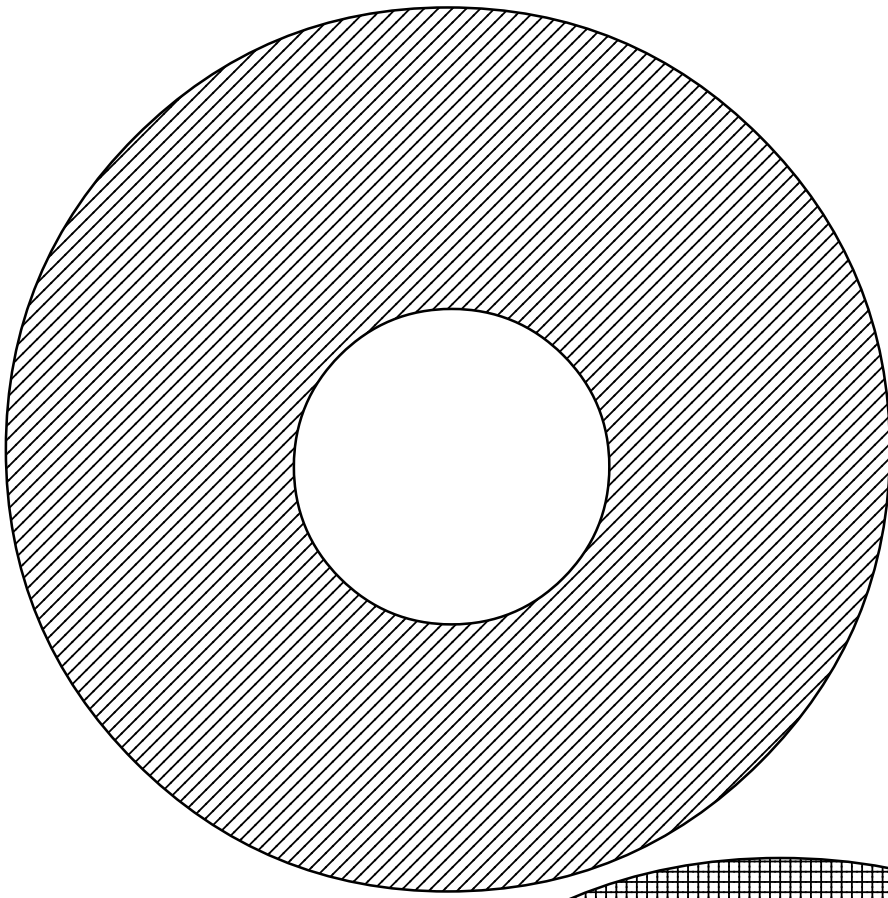

Towers of Hanoi

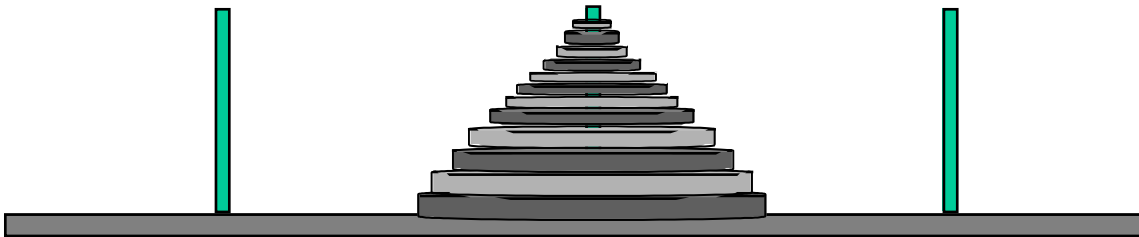

There is an ancient legend that in the great tower of Hanoi there stand three diamond spindles. On the middle one there is a stack of 64 golden disks of different sizes, each one smaller than the one below it. Monks in the temple have the task of moving the disks from one spindle to another, but they can move only one disk at a time, and they can never place a larger disk on top of a smaller one. The legend says that when this task is complete, the temple will disappear in a clap of thunder and the world will end. If the monks are very efficient and move these disks in the quickest way possible with each move lasting only one second, how long do we have until the world ends?

To find out how long we have until the world ends, start with a smaller problem and search for a pattern. If there was only one disk, how many moves would it take to transfer that? What if there were only two disks? Fill in the table below.

Number of disks	Minimum number of moves
1	_____
2	_____
3	_____
4	_____
5	_____
6	_____
7	_____

Can you find a pattern? According to the legend, how long do we have until the world ends?

Name _____ Date _____

Prickly Gift

On the planet Vulcan, there is an especially long-lived species of cactus. When each cactus is one year old, it produces exactly two offshoots (baby cacti) and then never reproduces again. Mr. Spock gives Captain Kirk a newly sprouted cactus plant which he gives to his nephew in Iowa. Complete the chart to find out how many cacti there will be in the following years.

YEAR	NEW CACTI	TOTAL CACTI
0	1	1
1	2	3
2		
3		
4		
5		
6		
7		
N		

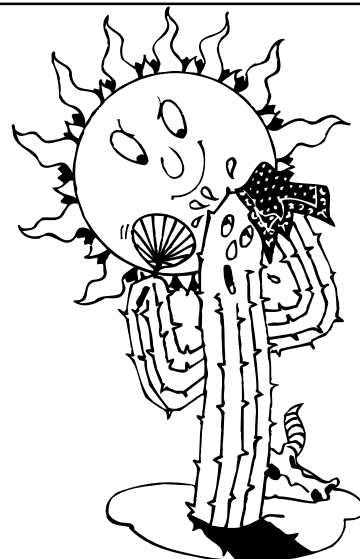

Solving Equation

For problems 1 - 6, write an equation and solve. Show all work.

1. Jamal and Joey scored a total of 65 points in a basketball game. Jamal scored 36 points. How many points did Joey score?
2. Ninety-nine dollars is needed to buy the new game system. Dave has \$46.00. How much more money does he need?
3. Brittany scored an 85 on her Math test. The average score of her class was 92. How many points under the average was she?
4. Niki scored a 78 on her first test and an 85 on her second. Niki forgot what she received on her third test, but she knows her average is an 85. What did she score on her third test?
5. The cost of buying Amusement Park tickets online can be found using the formula $c = 25t + 8$, where c is the total cost of purchasing the tickets, \$25 is the cost for each ticket, t is the number of tickets purchased, and \$8 is the online charge for ordering the tickets. What is the total cost for a family of 5 to go to the Park?
6. You get hired for a new job as a car salesman. You will get paid a weekly salary of \$600 plus \$150 commission on each car you sell. How many cars do you have to sell to be able to buy a \$1000 item that you want?
7. Write a problem that could go with the equation $f = 3.75c + 5.50$
8. A train is traveling at a speed of 75 miles per hour. What do the variables x and y represent in the equation $y = 75x$?

If you are on the train for an hour and a half, how far have you traveled?

Creating Tables, Graphs, & Equations

1. Kelli makes \$5.00 per hour at her after school job. Complete the chart relating the hours Kelli worked and the pay that she received.

a.

HOURS									
PAY									

b. Graph the ordered pairs in the chart from part a on the graph below. Remember to label your axes and set the intervals.

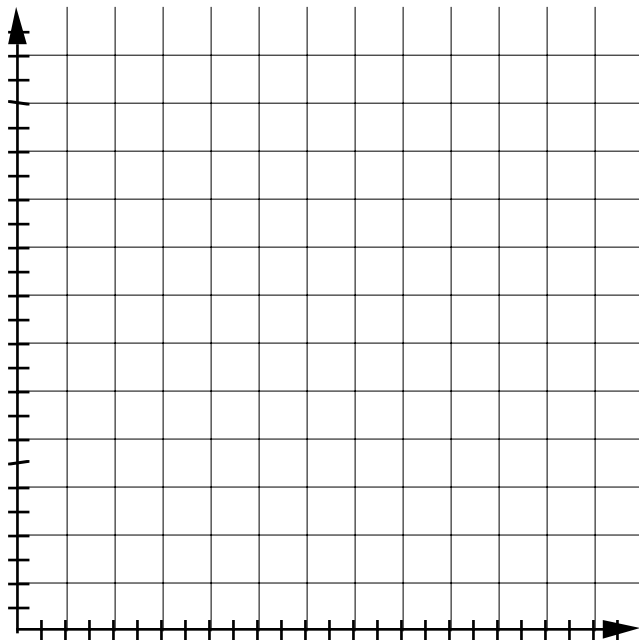

c. Write an equation for this situation: $P =$ _____

d. If Kelli worked 40 hours in a week, how much money will she make? _____

e. If Kelli earned \$105, how many hours did she work?

2. Raniqua's sister, Amy, is three years younger than Raniqua. Complete the chart relating Raniqua's age to Amy's age.

a.

RANQUA									
AMY									

b. Graph the ordered pairs in the chart from part a on the graph below. Remember to label your axes and set the intervals.

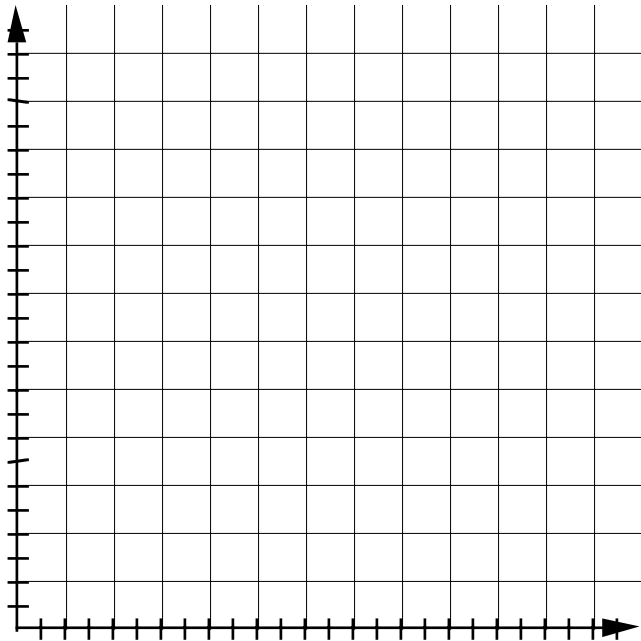

c. Write an equation for this situation: $S =$ _____

d. If Raniqua is 14 years old, how old is her sister? _____

e. When Raniqua's sister was 5 years old, how old was Raniqua? _____

Name _____ Date _____

3. In math class, there are four students in each group. Complete the chart relating the number of students and number of groups needed.

a.

# OF STUDENTS									
# OF GROUPS									

b. Graph the ordered pairs in the chart from part a on the graph below. Remember to label your axes and set the intervals.

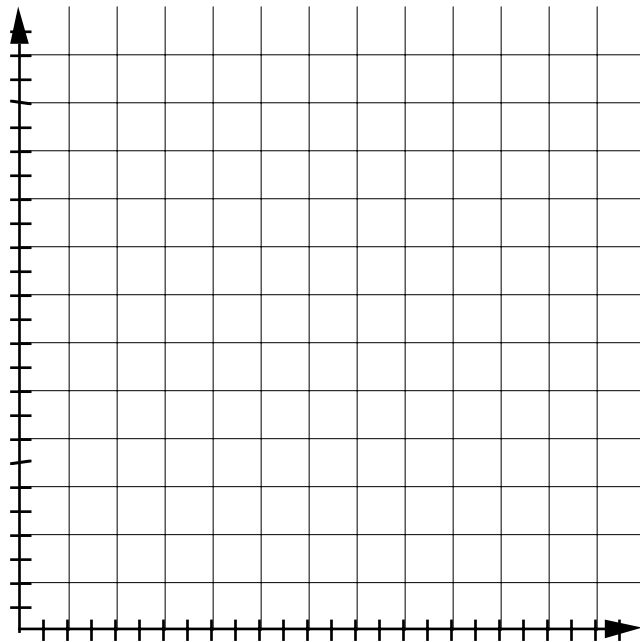

c. Write an equation for this situation: $G =$ _____

d. If Miss Cline has 28 students in her class, how many groups will she need? _____

e. If Miss Cline has eight groups, what is the largest number of students she can have? _____

4. On the last math test, Miss Cline added 7 points to the test grades of students who won the review game. Complete the chart relating original test grades and test grades after the bonus.

a.

ORIG. GRADE									
GRADE AFTER BONUS									

b. Graph the ordered pairs in the chart from part a on the graph below. Remember to label your axes and set the intervals.

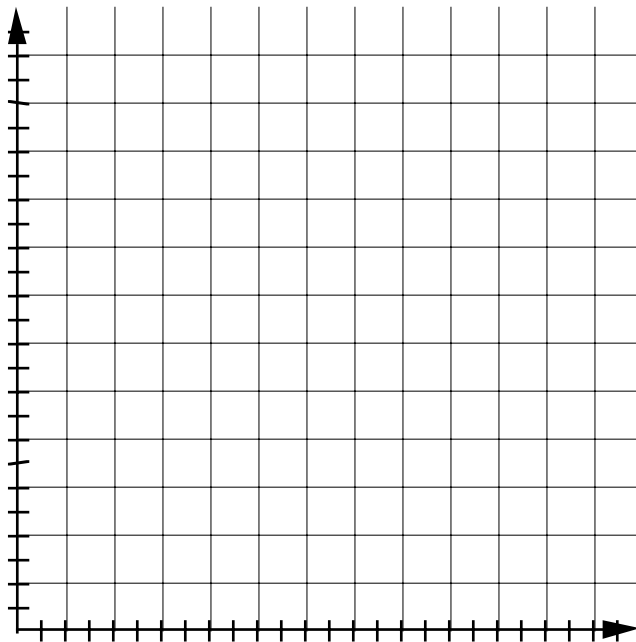

c. Write an equation for this situation: $B =$ _____

d. Jackie earned an 88 on the test. What was her grade after the bonus points were added?

e. Michael's grade after the bonus points were added was 85. What was his original test grade?

Toothpick Task One

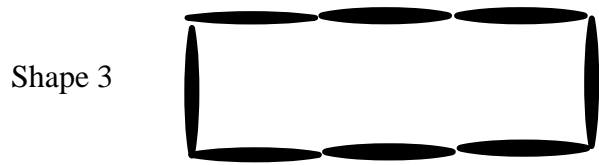
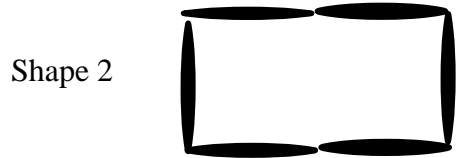
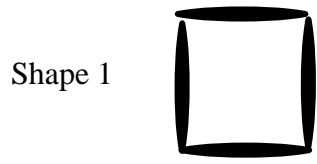

Shape #	Perimeter	Area
1	4	1
2	6	2
3		
4		
5		
6		
7		
8		
9		
10		
11		
12		
N		

Toothpick Task Two

Shape 1

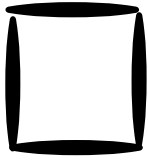

Shape 2

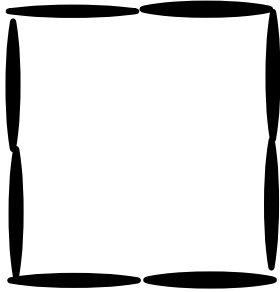

Shape 3

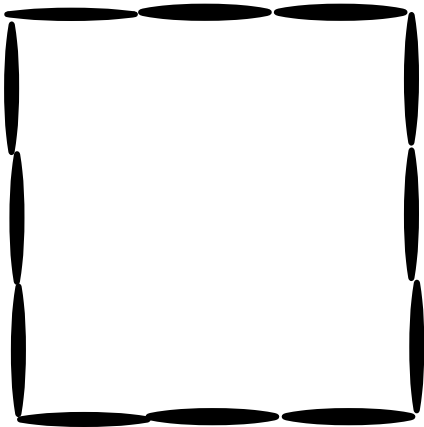

Shape #	Perimeter	Area
1	4	1
2	8	4
3		
4		
5		
6		
7		
8		
9		
10		
11		
12		
N		

Toothpick Task Three

Shape 1

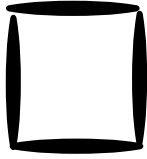

Shape 2

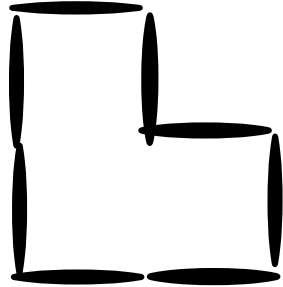

Shape 3

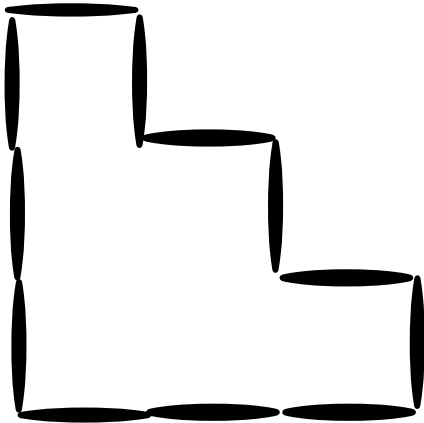

Shape #	Perimeter	Area
1	4	1
2	8	3
3		
4		
5		
6		
7		
8		
9		
10		
11		
12		
N		

Algebraic Expressions Square Puzzle

$3x+5$ $2x+3$	$3x-6$ $(2-x)3$	$3x+3$ $(3+x2)-1+x$	$3x+1$ $-x-2$
$-x-3$ $2-x$	$-x-1$ $16-3(x+5)$	$2x-4-(4x-1)$ $(2+x2)^{2/1}$	$-3(x+2)$ $x+1$
$x-2$ $1-x$	$2x+1+(x-6)$ $-1(3+2x)$	$10+(x-13)$ x^2-9-	$6-3x$ $(x-10)+(4-3x)$
$4-x-(2x)$ $2-3x$	$9+2x$ $5x-2-(8x-1)$	$(x^2-9)^{2/1}$ $x-1$	$1-x3$ $2x+1+(x+3)$
$4-3x$ $4x+1$	$2(3+x)$ $1-x3-$	$-3-4x$ $3-2x$	$3(x+4)-13$ $9+3x$

Cut out the squares above. Fit the squares together so that touching edges are equivalent.

Heaps and Holes - Modeling Variables

The giant's wife from the story of Jack and the Beanstalk likes to make surprises for the boys who venture to climb to the top of the beanstalk. Each morning she wraps up several boxes with magic beans inside. The beans are invisible, so no one can look inside and see how many are there. Some days she puts hundreds of beans in each box. Some days she puts only 4 beans in each box. Some days she will put only $\frac{1}{2}$ a bean in each box. The boxes she wraps up each day all have the same number of beans. So she can remember how many are inside, she labels each box with a secret code letter. Each box marked with the same letter has the same number of beans inside.

Write a variable expression for the number of beans pictured here.

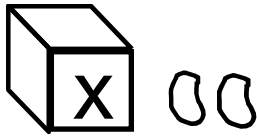



1. Do you think that $3x + 2$ and $5x$ are the same? _____

Draw a diagram to represent each expression.

$3x + 2$ _____

$5x$ _____

2. Is $4x + 0$ different from $4x$? _____

Draw a diagram to represent each of these expressions.

$4x + 0$ _____ $4x$

3. Is $1(2x+3)$ different from $2x+3$? _____

Draw a diagram to represent each of these expressions.

$1(2x+3)$ _____ $2x+3$

4. Is $3(x + 1)$ the same as $(3x + 1)$? _____

Draw a diagram to represent each of these expressions.

$3(x + 1)$

$(3x + 1)$

5. Draw a diagram to represent $(2x + 1)$ and $(3x + 1)$.

$2x + 1$

$3x + 1$

What is $(2x + 1) + (3x + 1)$? _____

We can use the heaps and holes drawings to add expressions involving negative values.

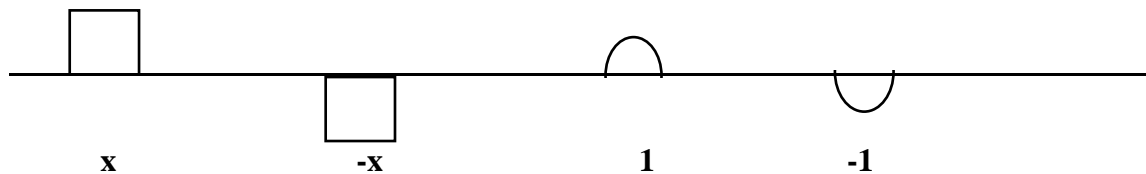

6. Draw a diagram to show the result of adding $(3x + 2)$ and $(2x - 4)$.

7. Draw a diagram to show $(3x - 2) + (5 - x)$.

8. Draw a diagram to show $(x + 2) + 2(3 - x)$.

What about subtraction?

$$(3x - 4) - (2x + 1)$$

Start with $(3x - 4)$.

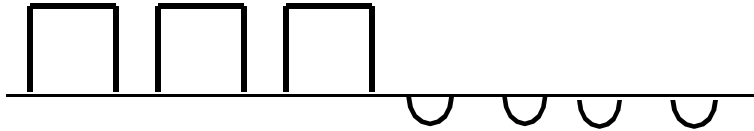

You could take away $2x$, but there is not a $(+1)$ to take away. We fix this by adding a zero.

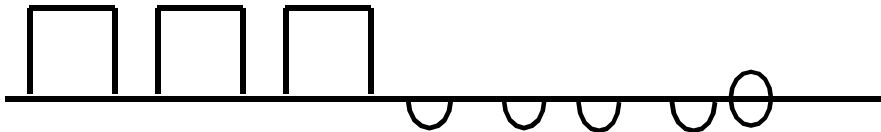

Now we can take away $2x$ and 1. The answer is $x - 5$.

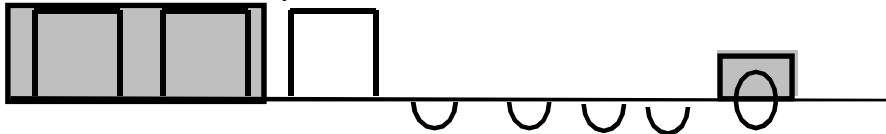

9. Draw a diagram to illustrate $(x - 4) - (2x + 3)$.

10. Draw a diagram to illustrate $2(x + 2) - (3 - x)$.

Patterns in Perimeter

If each side of the first figure in each set has a length of one unit, what is the perimeter of the other figures in each set? Fill in the table accompanying each set of figures.



1



2



3



4

I. Triangles	1	2	3	4	5		10				n
Perimeter											

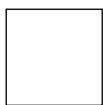

1



2



3



4

II. Squares	1	2	3	4	5		10				n
Perimeter											

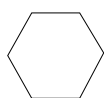

1

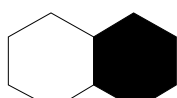

2

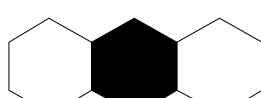

3

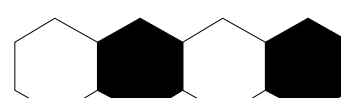

4

III. Hexagons	1	2	3	4	5		10				n
Perimeter											

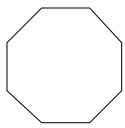

1

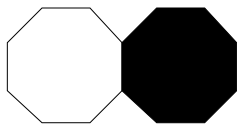

2

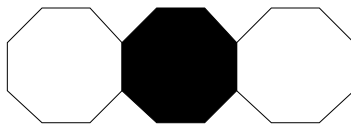

3

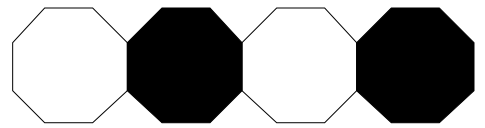

4

IV. Octagons	1	2	3	4	5	10		n
Perimeter	8	14					440	

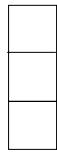

1

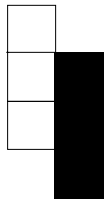

2

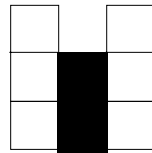

3

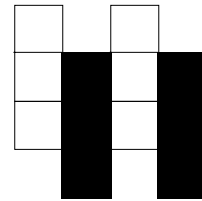

4

V. 3-Squares	1	2	3	4	5	10		n
Perimeter	8						256	

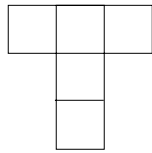

1

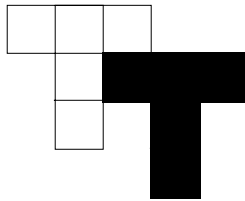

2

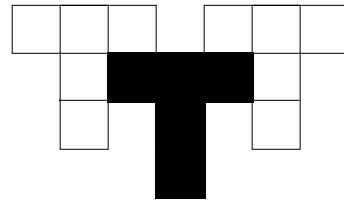

3

VI. T-Squares	1	2	3	4	5	10		n
Perimeter	12						268	

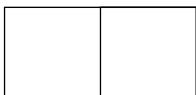
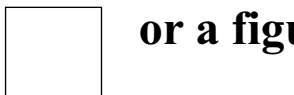
VII. Use  **or**  **or a figure of your own**

to make a sequence of shapes to be shared and analyzed.

Lining Up Dominoes

START	$2(x-3)$	$2x-6$	$-9(8x-y)$	$-72x+9y$	$-(3x-1)$	$-3x+1$	$9(8x-y)$
$72x-9y$	$-2(x-3)$	$-2x+6$	$-12(-x-2y)$	$12x+24y$	$-4(x+6)$	$-4x-24$	$2(x+6)$
$2x+12$	$4(x+6)$	$4x+24$	$-5(2y+3x)$	$-15x-10y$	$-(3x+1)$	$-3x-1$	$12(x-2y)$
$12x-24y$	$2(x+3)$	$2x+6$	$-3(4x-y)$	$-12x+3y$	$-2(x+3)$	$-2x-6$	$-7(8x-9y)$
$-56x+63y$	$-4(x-6)$	$-4x+24$	$3(4x+y)$	$12x+3y$	$-8(4-x)$	$8x-32$	$-12(x+2y)$
$-12x-24y$	$6(2x+6)$	$12x+36$	$5(2y-3x)$	$-15x+10y$	$4(x-6)$	$4x-24$	$-12(x-2y)$
$-12x+24y$	$7(8x+9y)$	$56x+63y$	$12(3x-1)$	$36x-12$	$8(4-x)$	$-8x+32$	$3(4x-y)$
$12x-3y$	$2(x-6)$	$2x-12$	$4(x-3)$	$4x-12$	$-9(-8x-y)$	$72x+9y$	STOP

Lining Up Dominoes
Master Sheet

How Do They Fit?

$n = 15$ $n + 7 = -11$ $n + 4 = 7$ $n = -20$	$n = 31$ $n + 7 = -13$ $n = -48$ $n = 23$	$n - 48 = -17$ $n - 38 = -15$ $n - 17 = 3$ $n - 5 = -30$
$n = 3$ $n = -34$ $n - 8 = -15$ $n - 26 = -8$	$n = 20$ $n - 9 = 11$ $n = -39$ $93 - 12 = 21 + n$ $81 = n$	$n = 20$ $n - 5 = -16$ $n + 25 = -23$ $22 - 17 = 21 + n$
$n = -7$ $n = 18$ $n - 7 = -14$ $n = -25$	$n = 20$ $n - 5 = 9$ $n + 19 = -5$ $21 - 13 = 31 + n$	$n = -11$ $n + 5 = 8$ $n = -39$ $41 = n$

How Do They Fit?
Master Sheet

How Do They Fit?
Solve linear equations.

$x + L = (L + x)4$ $5f - \frac{1}{2} = 4f = \frac{3}{4}$	$3d - 8 = -6 + d$ $2y + 5 = y - 4$	$4 + m = m$ $7 - 5 = 8j + 7$
21 1	$11e = 9e + 14$	7 $\frac{1}{2}$
$\frac{4}{5}$	6^-	2^-
100 2 $p d - 3d = -2d + d - 3d$	22 $6n = 4n + 20$ $4 - 9j = j + 4$	0 $4B - 10 = B + 3B - 2B$ $7m = -30 + m$
$u^2 + 9 - u^5 = u^4$	01	5
$-5a + 7a = -18 + 3a + 5a$ $\frac{2}{9}$	$5d - 4 = 2d + 6$ $8 - 5a = 3a$ -9	$3m + 6 = m - 6$ -11

Equation Relays

1.) $2x + 3x = 25$

2.) $5m - 8m = 36$

3.) $4(7x - 3) = 16$

4.) $25 = 5(2t - 7)$

5.) $10n - 8 + 4n = 20$

6.) $4a + 8 - a = 80$

7.) $15r - 18r = 687$

8.) $3(m + 1) + 2m = 88$

9.) $7(3k + 4) - 18k = 64$

10.) $10 = 10(y - 5) + 5y$

11.)

12.)

13.)

14.)

15.)

16.)
